

TECHNICAL PRODUCT INFORMATION

MAX

MXSBFC-L

WALL MOUNTED SWIVEL BASIN / BATH MIXER (LONG)

FEATURES & BENEFITS

- For all pressures when installed as basin mixer
- For equal pressure only when installed as a bath mixer
- Features 180° swivel spout and pivoting aerator included
- Ideal for kids' safety in bath while maximising space
- 40mm quality European cartridge
- Designed in New Zealand
- Watermark certified
- 10 year warranty & lifetime extension warranty available

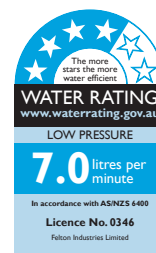
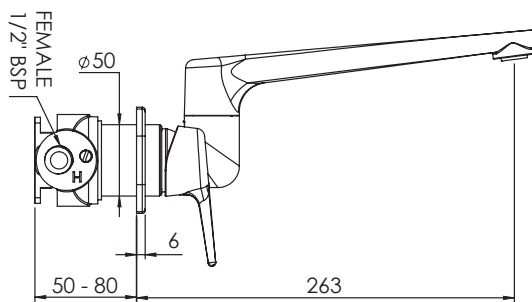
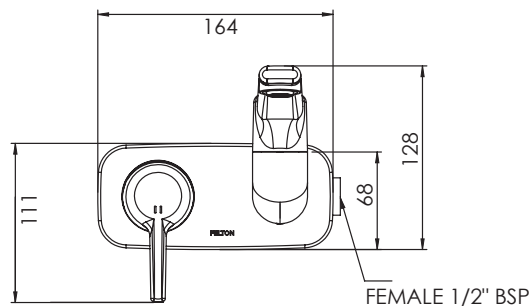

APPLIES WHEN INSTALLED AS BASIN MIXER