

TECHNICAL PRODUCT INFORMATION

AXISS

AXSBFC

WALL MOUNTED SWIVEL BASIN/BATH MIXER

FEATURES & BENEFITS

- For all pressures when installed as basin mixer
- For equal pressures only when installed as a bath mixer
- Features 180° swivel spout
- Ideal for kids safety in bath while maximising space
- 40mm quality European cartridge with anti-scald and flow limiter
- Designed in NZ
- 10 year warranty & lifetime extension warranty available

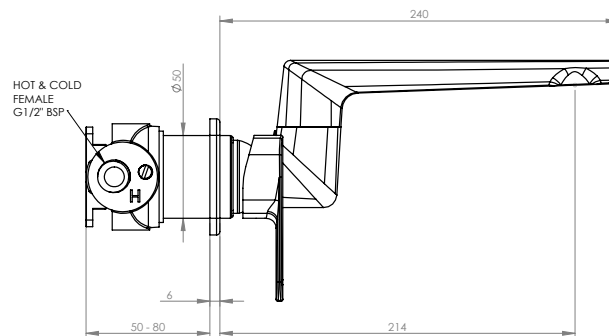
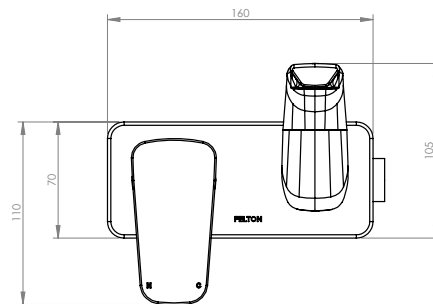

WHEN INSTALLED AS BASIN MIXER