

FELTON

TECHNICAL PRODUCT INFORMATION

TATE

WALL MOUNTED BASIN/BATH MIXER

FEATURES & BENEFITS

- Suitable for mains pressure only (up to 500kPa)
- Available in chrome, black & PVD finishes
- 35mm quality European cartridge
- Suitable for left or right-handed installation
- Designed in NZ
- Watermark certified
- 20 year warranty (T&C's apply)

NEW ZEALAND REGISTERED DESIGN NO. 426071, NO. 426072 & NO. 427630

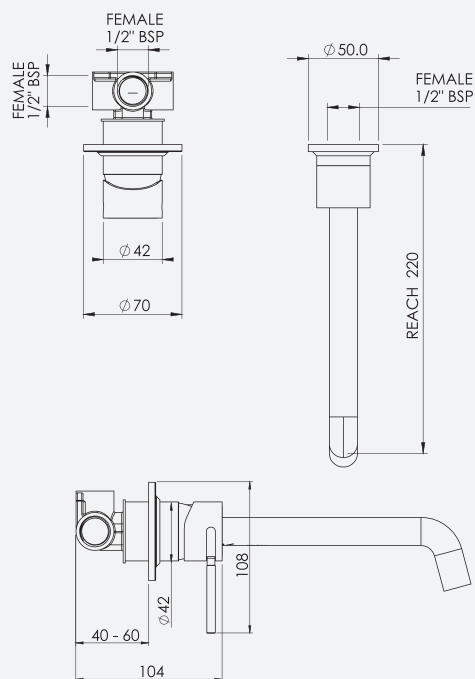

Chrome | NZ TBFC
AU TBFCA



Black
NZ TBFMB
AU TBFMBA



Brushed Stainless Finish
NZ TBFBN
AU TBFBNA



Brushed Gunmetal
NZ TBFGM
AU TBFGMA



Brushed Gold
NZ TBFBG
AU TBFBGA



Brushed Bronze
NZ TBFBZ
AU TBFBZA



Brushed Bronze / Black
NZ TBFBZ-MB
AU TBFBZ-MBA