

# FELTON

## TECHNICAL PRODUCT INFORMATION

### TATE

### TALL BASIN MIXER

#### FEATURES & BENEFITS

- Suitable for mains pressure only (up to 1500kPa)
- 25mm quality European cartridge
- Available in chrome, black & PVD finishes
- Designed in NZ
- Manufactured from lead free materials
- 20 year warranty (T&C's apply)

NEW ZEALAND REGISTERED DESIGN NO. 426071, NO. 426072 & NO. 427630

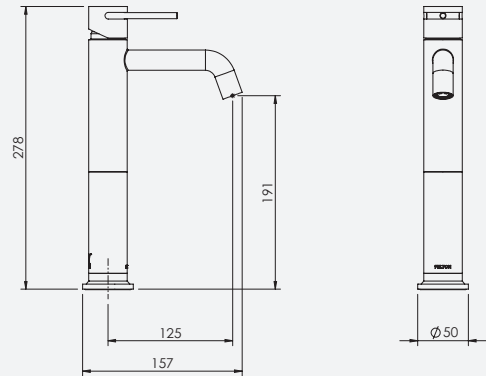

Chrome | NZ TTBMCA  
AU TTBMCB



Black  
NZ TTBMBA  
AU TTBMBB



Brushed Stainless Finish  
NZ TTBMBN  
AU TTBMBNA



Brushed Gunmetal  
NZ TTBMGM  
AU TTBMGMA



Brushed Gold  
NZ TTBMGB  
AU TTBMGGA



Brushed Bronze  
NZ TTBMBBZ  
AU TTBMBBZA