

FELTON

TECHNICAL PRODUCT INFORMATION

TATE

DIVERTER MIXER

FEATURES & BENEFITS

- Suitable for mains pressure only (up to 500kPa)
- Available in chrome, black & PVD finishes
- 35mm quality European cartridge
- Switch between two water outlets
- Designed in NZ
- Watermark certified
- 20 year warranty (T&C's apply)

NEW ZEALAND REGISTERED DESIGN NO. 426071, NO. 426072 & NO. 427630

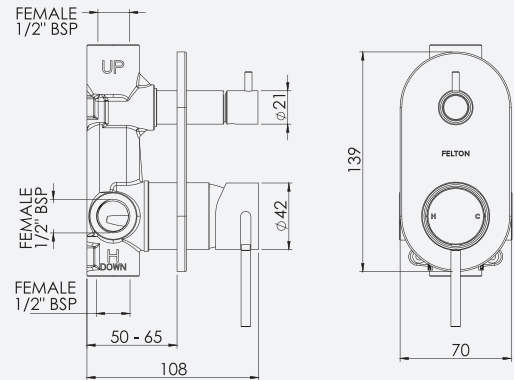

Chrome | NZ TDCSMC
AU TDCSMCA



Black
NZ TDCSMMB
AU TDCSMMBA



Brushed Stainless Finish
NZ TDCSMBN
AU TDCSMBNA



Brushed Gunmetal
NZ TDCSMGM
AU TDCSMGMA



Brushed Gold
NZ TDCSMBG
AU TDCSMBGA



Brushed Bronze
NZ TDCSMBBZ
AU TDCSMBBZA



Brushed Bronze / Black
NZ TDCSMBBZ-MB
AU TDCSMBBZ-MBA