

FELTON

TECHNICAL PRODUCT INFORMATION

QUE

RAIN HEAD WALL MOUNTED (450mm)

FEATURES & BENEFITS

- For all pressures (min 35kPa)
- Available in chrome & black
- Shower aperture - 89mm²
- 300 x 200mm stainless steel rainhead
- 450mm horizontal reach (from flange to outlet)
- 1/2 inch female thread
- Watermark certified
- 5 year warranty (T&C's apply)

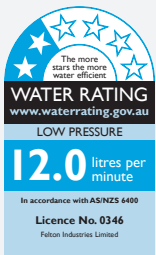
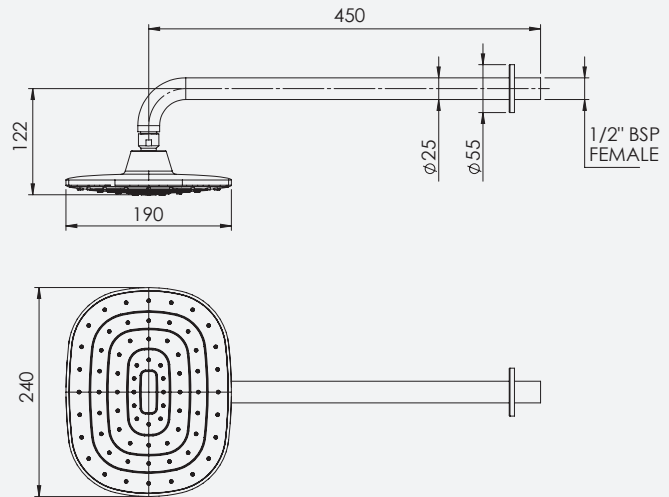

Applies to NZ only



Black
NZ QRHWMB
AU QRHWBMA



Chrome | NZ QRHWMC
AU QRHWMCA