

## 50 YEARS *of* FELTON



### INSIDE THIS ISSUE

---

Looking Back: 50 Years of Tapware and Innovation

Designer III: A classic story of Kiwi innovation

Ease leaking shower worries

+ More

# Celebrating 50 Years



In this issue of News on Tap we are in celebration mode.

I'm proud to be part of this innovative, New Zealand company as we reach a substantial milestone: 50 years and counting.

From the outset, Felton has epitomised classic Kiwi ingenuity. Combining innovative design and manufacturing to suit our NZ conditions.

As always, there's room to adapt and improve. The anniversary-timed release of the Max range is an example

of how we're adapting our range lines to meet changing needs as space becomes a premium in Kiwi homes.

I hope you enjoy reflecting on the Felton story.

Thank you for your support and your time in reading this update.

Roger Marty  
*General Manager*

# Looking Back: 50 Years of Tapware and Innovation



Above from left: Max Davies, Peter Johnson and Keith Relf contemplate the Feltonmix



Photo: Max Davies

The entrepreneur's dream is to meet a market need in a new, compelling and enduring way.

Felton's founder Max Davies was already past retirement age when he founded the company. Despite not being formally trained, and having left school at 14, Max had previously owned a successful electrical element manufacturer, Hermetic Ltd.

Through Hermetic Ltd (now Zip Plumbing), he met Keith Relf from Victor Industries and they agreed to further develop and manufacture Keith's concept for a new type of shower mixer. The rest, as they say, is history!

Max Davies passed away in June 1995 at 93 years old, having worked at Felton right up until age 91. Few of the people whose lives his work improved know of him and his legacy. And yet his impact was — and is — substantial. We are humbled and proud at Felton to build on Max's founding legacy in working with you.

**1968**  
Felton formally registered on 23rd September by Max Davies at Felton Matthew Avenue - the street address being the basis of the company's name.

**1969**  
Launched Feltonmix™ technology - the first shower mixer to work on unequal water pressure.

**1979**  
Manufactured first isolator valve made completely from engineering plastics.

**1985**  
Apricot colour added to the Caroma colour range of Ivory, Avocado, Red, Royal Blue and Chocolate.

**1987**  
Introduced the first plastic bodied shower mixer using engineering plastics and sealing system.

**1990**  
The first Felton slide rail manufactured in NZ.

**1991**  
Passed the Australian MP52 and given permission to use Watermark.

**2001**  
Venturi exposed outlet shower mixer engineered, launched and manufactured in New Zealand.

**2002**  
Felton's first stainless steel slide rail with patented mounting system manufactured in New Zealand.

**2003**  
Felton became the first NZ Company to exhibit at ISH Frankfurt (Germany), the industries' biggest international trade fair.

**2004**  
Venturi concealed outlet shower mixer launched.

**2005**  
Moved to bigger premises on Farmhouse Lane Glen Innes, after almost 40 years at Felton Matthew Ave.

FX Architectural stainless steel shower towers developed and launched at ISH Frankfurt.

**2007**  
First high-temperature glass-filled nylon bodied ceramic cartridge shower mixer developed and made in NZ.

FX Architectural 'Tree' heated towel rail developed and made in NZ.

FX Architectural Showerspace launched at DesignEx.

**2008**  
Glu system patented and launched.

**2009**  
SmartFlow™ All Pressures Thermostatic Shower Mixer developed and launched.

**2010**  
Versadisc™ All Pressures Shower Mixer developed and launched. Awarded Best Design Silver for conceptual product.

**2013**  
Oxijet™ water saving product developed and launched. Best Design Finalist for sustainable product.

**2015**  
Fusion Plus™ Shower Mixer developed and launched.

Axis range tapware awarded Best Design Bronze for consumer product.

**2016**  
Axis Touch Tap and Fusion Plus™ won Bronze at Best Design Awards for consumer category.

Feltonmix™ Designer III wallsets and shower head launched.

**2017**  
Felton Digital thermostatic shower mixers, Smartview and Smartflow launched.

**2018**  
23rd September marks the official date of Felton's 50th milestone.



## Designer III: A classic story of Kiwi innovation

The Designer range centres around the Feltonmix™ shower mixer. It was the very first of its kind in New Zealand to apply the Venturi principle to successfully mix hot and cold water supplied at different pressures.

Having sold more than 1.7 million mixers in the 50 years since it was developed, the Feltonmix has earned the trust of New Zealand plumbers and homeowners, and it continues to prove its reliability and performance time and time again.

### STILL PROUDLY 100% DESIGNED & MADE IN NEW ZEALAND

'86 Feltonmix™ Mixing Valve:

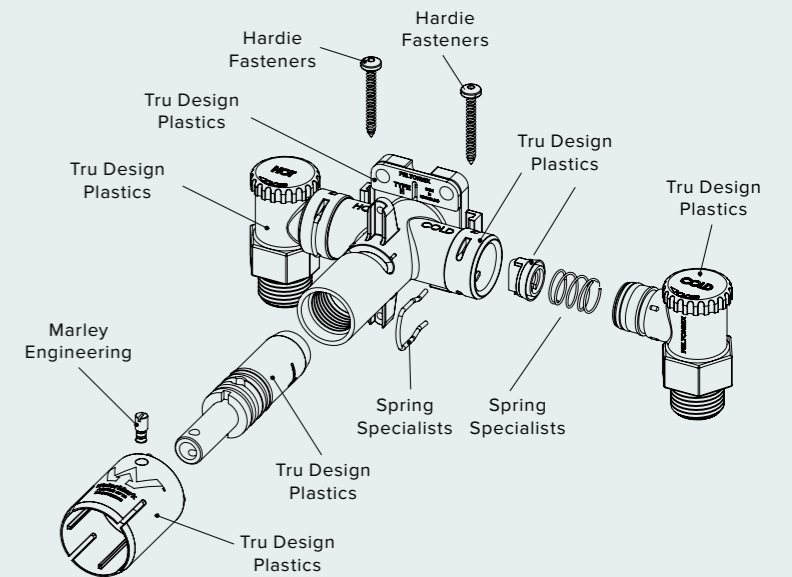

Designer III Wallset:

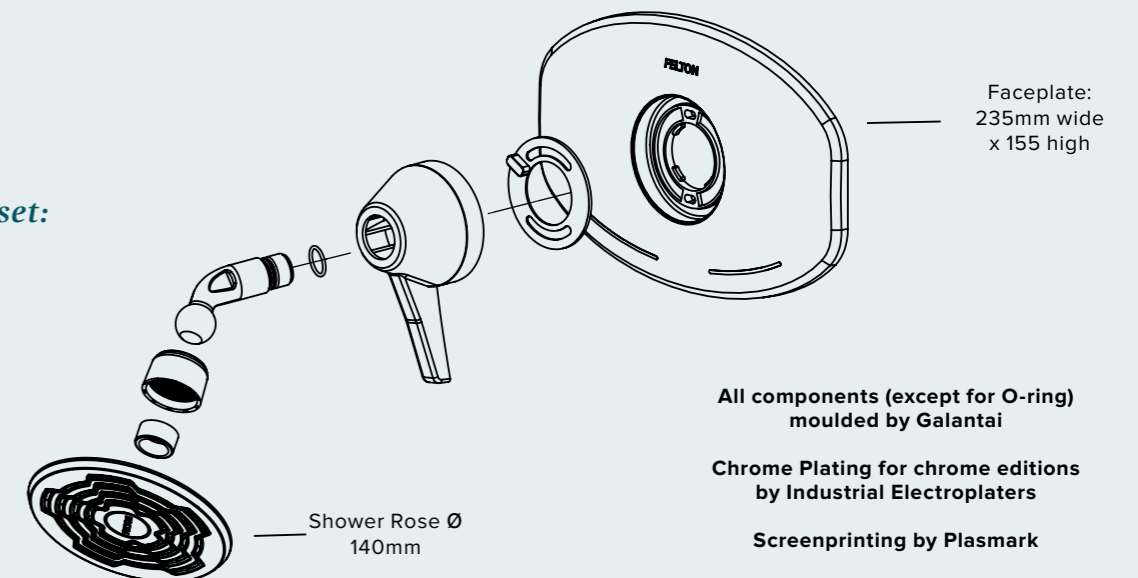

*A look behind the scenes at how it's made:*



From left to right, top to bottom: 1 Friction welding the rotor • 2 Fixing the rotor into the mixer body • 3 Inspecting an assembled Designer '86 Feltonmix™ Mixing Valve • 4 Pressure testing the mixing valve • 5 Fixing the control sleeve onto the mixing valve • 6 Engraving the Felton logo and the hot/cold indicators onto the Designer faceplate • 7 Assembling components of the Designer III shower rose ready for sonic welding • 8+9 Designer III shower rose fresh out of the sonic welding machine

*FROM THE ARCHIVES:*

Since launching the original wallset, the Feltonmix™ has been through constant design improvements over the years.



**1969**

Launched Feltonmix™ technology - the first shower mixer to work on unequal water pressure.



**1970**

A range of colours matching Caroma products became available: Ivory, Avocado, Red, Royal Blue and Chocolate.



**1979**

Manufactured first isolator valve made completely from engineering plastics.



**1985**

Wallset designed by Gifford Jackson. Caroma Apricot colour added to range on offer.



**1986**

Introduced the first plastic bodied shower mixer using engineering plastics and sealing system.



**1987**

Ironically the Feltonmix '86' mixer wasn't launched until February 1987.



**1998**

The Designer wallset was launched. A variety of colours were available - Chrome, White, Ivory, Mist Grey, Apricot and Gold.



**2000**

The Designer II was released.



**2016**

Designer III launched with a few product improvements: a wider faceplate and shower head to give full coverage.

## Celebrating 50 years with the release of Max

The new Max range innovates to meet changing market needs, without compromising on form, function and aesthetic appeal.

We've launched this range, named after our company founder Max Davies, to coincide with our 50th anniversary.

Affordability, flexibility and functionality are paramount in the Max range which includes a range of basin mixers, sink mixer, shower mixers, wall mounted basin bath mixers and baths spouts.

The wall mounted basin bath mixers and the bath spouts feature a 180° swivel spout and are available with three different spout lengths to suit every space

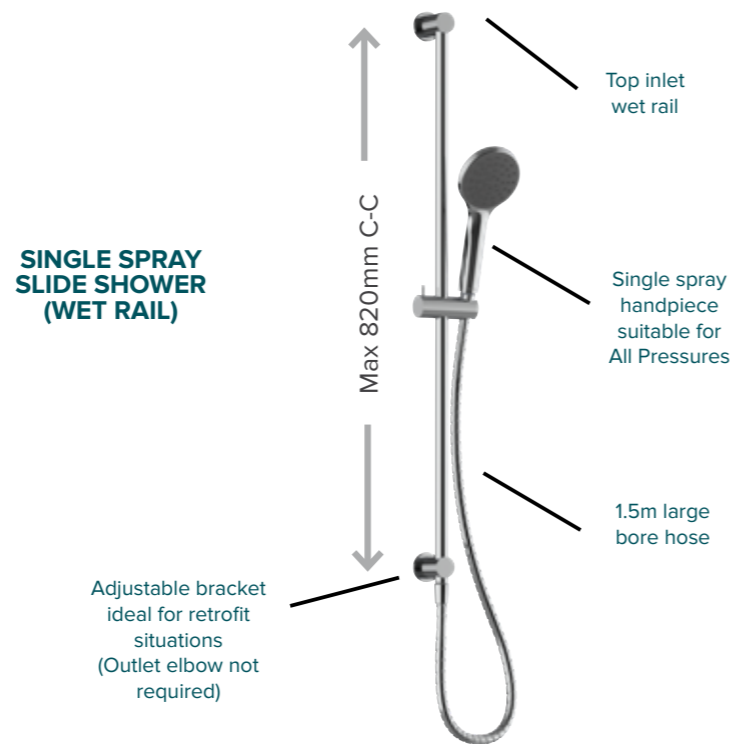

### BASIN MIXERS



### WALL MOUNTED SWIVEL BASIN / BATH MIXERS



### BATH SPOUTS

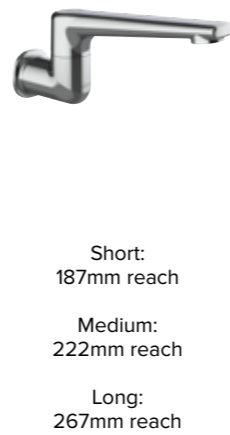

## Ease leaking shower worries

Water leaking into walls can cause a number of problems, not least of which – mould growth – is a serious health issue. With such an accessible solution, is it really worth the risk?



Damage caused by leaking shower installations can be devastating to homeowners – not just from a structural and financial point of view but health-wise as well.

Aquatite is an innovative NZ company which offers customers the Wetwall Caddy™, a molded ABS plastic device that encloses water control valves and plumbing connections, and protects the wall cavity from any potential leaks that may occur.

Aquatite's focus is to provide a product to property developers, architects and those in the trade industry so they can ensure the highest standard of protection in both existing and new homes. The Wetwall Caddy™ was developed as a solution to the ongoing problem of leaking showers and is proud to be sustainable as well as compliant to both NZ Building Code E3 internal moisture and AS374. And it ensures that access holes are sealed.

The Waterproofing Membrane Association (NZ) Inc. have a Code of Practice which gives clear instruction on dealing with membrane penetrations. Shower mixers /outlets require either a proprietary "Wet Wall Caddy" fitted to manufacturer's instructions or the waterproofing membrane sealed up to the penetration.

The purpose of this Code of Practice is to apply best industry practice to ensure that the requirements of NZBC Clause E3 Internal Moisture, and accompanying Acceptable Solution E3/AS1 are met and sometimes exceeded. This Code of Practice is also applicable to buildings outside of E3, such as commercial food preparation areas.

All wet areas containing a water supply must:

- Be protected with a wet area membrane
- Be contained by a waterstop
- Have all penetrations sealed

The over-arching principle must always be to design for any potential situation where there could be water spillage and that the membrane should be carried behind wall mounted fittings from the floor up the wall to at least the point of entry through the wall of the plumbing fitting.

**AQUATITE WET WALL CADDY**

As well as preventing water damage, the Wetwall Caddy™ adds real value by empowering homeowners with information if they have a water leak on their hands.

Find out more at [www.wetwallcaddy.nz](http://www.wetwallcaddy.nz)

## Felton Digital - Scope of Application

Smartflow & Smartview are digital thermostatic shower mixers featuring Swiss technology which allows you to alter your water temperature & flow comfortably at the touch of a button.

There are three programmable memory settings to customise your shower temperature & flow rate as well as the ability to set a maximum temperature. The thermostatic mixers allow constant water temperatures even when other taps in the house are used, making for a safer shower, especially for children & the elderly.

Felton Digital Smartflow and Smartview come with a 5 year warranty and are available through specialist plumbing and bathroom distributors.

There is plenty of scope for application for both Smartflow and Smartview units, although ceiling mounted is the recommended option:

### SMARTFLOW + SMARTVIEW

#### A Ceiling Mounted Shower Handset (Recommended)

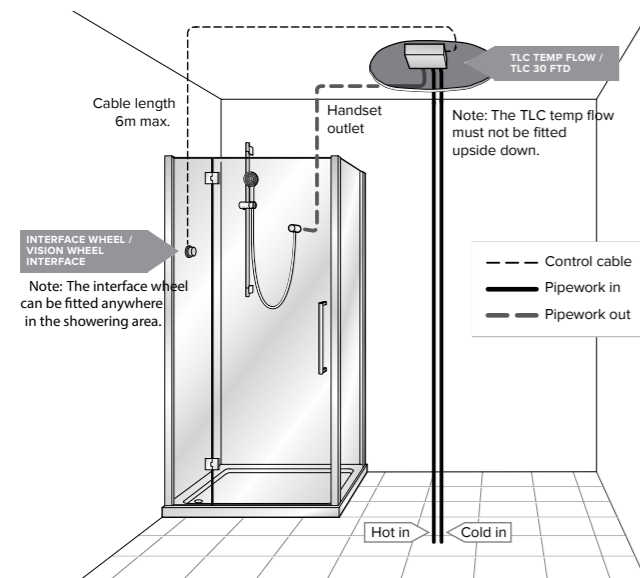

#### B Wall Mounted Shower Handset

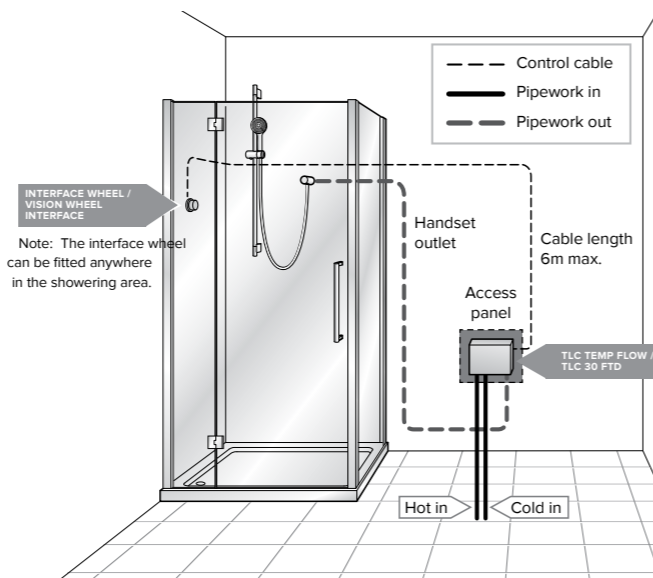

**Important:** The TLC Temp Flow / TLC 30 FTD must be accessible and should not be sealed in the wall



You can read about mechanical vs digital thermostatic mixers and the benefits of going digital in the June 2018 edition of our News On Tap.

Request this edition by emailing [trade@felton.co.nz](mailto:trade@felton.co.nz)



See more at [feltondigital.co.nz](http://feltondigital.co.nz)



## Wintec – 100th Student to be supported

This year we have continued our commitment towards encouraging and supporting prospective apprentices in the Plumbing and Gasfitting industry with the Pre-Trade apprenticeship course being run at the Waikato Institute of Technology.

The Felton Pre-Trade Apprenticeship Sponsorship Scheme was set up in 2002 to financially assist a potential apprentice that displays excellent practical and theory skills, a good technical understanding of Plumbing and Gasfitting, and a positive attitude.

As one of four finalists for the Felton Sponsorship package, and the top placed candidate, Nicola Carruthers is the 100th student that we've supported through this program.

Congratulations to Nicola and the other finalists!



## Felton Digital Display

Felton Digital by Felton – Our Smartflow and Smartview digital thermostatic mixers are now on display at the Home Ideas Centre, Auckland

165 The Strand Parnell, Auckland  
[homeideascentre.co.nz](http://homeideascentre.co.nz)



## Movers + Shakers

### *Laura Greenaway* Service Engineer / Warranty Technician

Laura has recently joined Felton and will be offering technical support, advice and information. Before joining us, she served in the Royal New Zealand Air Force for 4 years as an Aircraft Mechanic. She is passionate about people and enjoys tinkering in the workshop.

We wish her a warm welcome to the Felton team!



## Felton Roadshow

We're excited to be a silver sponsor at the Mico CPD course this year. The events kick off in May 2019 and we're looking forward to showcasing our new Fusion Plus shower mixer.

Keep an eye on the Trade Events calendar on our website for confirmed dates and venues near you - [www.felton.co.nz/trade/#trade-events](http://www.felton.co.nz/trade/#trade-events)



## Social Media For Plumbers

### Facebook

Your resource for new ranges and product launches, technical info, FYIs, spare parts, tips and competitions. Follow us - Facebook/feltonindustriesslimited

### Instagram

An inspirational resource for product information as well as bathroom, kitchen, styling and lifestyle inspiration. Follow us - @feltontapware

[www.felton.co.nz](http://www.felton.co.nz)  
CALL 0800 743 358  
FAX 0800 329 335  
FIND US ON SOCIAL MEDIA

 /FeltonIndustriesLimited

 /felton-industries-limited

## Any Queries/Suggestions?

*"We value your feedback, so tell us what you think!  
We'd love to hear from you."*