

INSTALLATION GUIDE

SLIQUE SINK MIXER

SYSTEM REQUIREMENTS

To ensure the optimum performance and customer satisfaction please adhere to the following:

- Flush out all pipe work prior to installation.
- Maximum hot water temperature is 60°C. If the water temperature exceeds 60°C an approved tempering valve must be fitted.
- Installation should comply with relevant local authority requirements.
- In accordance with good plumbing practice, filters should be fitted to supply lines to eliminate damage to the ceramic cartridge from suspended solids.
- AS/NZS 3500.1 states that pressures above 500kPa can cause damage from water hammer, reduce the life of appliances, taps & fittings, cause excessive noise in the system and recommend that a pressure limiting valve (PLV) be fitted.
- Installation must be carried out by a registered plumber in accordance with AS/NZS 3500, the New Zealand Building Code and Felton instructions.
- Inspection and maintenance must be carried out in accordance with Felton instructions to ensure ongoing performance and compliance.

MAXIMUM STATIC PRESSURE
Maximum static pressure 1500kPa. If water pressure exceeds or is likely to exceed 1500kPa, an approved pressure limiting valve must be fitted.

MINIMUM STATIC PRESSURE	HOT	COLD
Mains Pressure	150kPa	150kPa
Unequal Pressure <i>(applies to NZ only)</i>	36kPa	150kPa
Equal Low Pressure <i>(applies to NZ only)</i>	36kPa	36kPa



Failure to comply with the above will void warranties

BUILDING PRODUCT INFORMATION REQUIREMENTS (BPIR)

RELEVANT BUILDING CODE CLAUSES & CONTRIBUTIONS TO COMPLIANCE

This product is Watermarked under license **WM25208 - Tapware (Lead free) AS 3718: 2021**

B2 - Durability

B2.3.1 (c) applies (performance of building elements)

Proof of durability – Service history: Felton products have been installed and used in NZ for the last 50 years and warranty calls are at a minimum and within the quality principles of Felton.

Products that are WaterMark certified are subject to endurance testing.

F2 - Hazardous building materials

F 2.3.1 applies (performance)

Products in contact with drinking water is tested to AS/NZS 4020 (ensures acceptance levels of contaminants for human consumption). Compliance with Lead Free and DR Lead Free requirements where applicable.

G12 - Water Supplies

G12.2 applies (materials)

Felton products in contact with drinking water are tested to AS/NZS 4020, ensuring no water contamination and compliance with Lead Free and DR Lead Free requirements where applicable.

G12.3.2 applies (contamination of water)

All Felton products are designed, manufactured and inspected/tested, that are WaterMark certified, are subject to contamination of water testing (AS/NZS 4020). Compliance with Lead Free requirements where applicable.

G12.3.5 applies (performance)

Felton sanitary fixtures intended for utensil washing and personal washing, showering, or bathing are designed to be connected to a hot water supply and tested to AS/NZS 4020, ensuring suitability for potable water, non-contamination, and compliance with the performance requirements of NZ Building Code G12.

G12.3.7 (c) applies (flow rates)

All Felton products are designed, manufactured and inspected/tested, that are WaterMark certified, are subject to flow rates testing that is within the limitation set by the AS/NZS 3500 (NZBC) and the WELS regulations.

G12.3.10 applies (performance)

Felton water supply taps are designed to be accessible and operable, including for people with disabilities, when installed in accordance with Felton's instructions, supporting compliance with the accessibility requirements of the NZ Building Code.

WHAT IS IN THE PACK

- | | |
|---------------------|---|
| 1 x sink mixer | 1 x flow straightener |
| 2 x supply hoses | 1 x key for aerator |
| 1 x sink fixing kit | 1 x male female brass nipple with flow restrictor prefitted |

IF YOU HAVE...

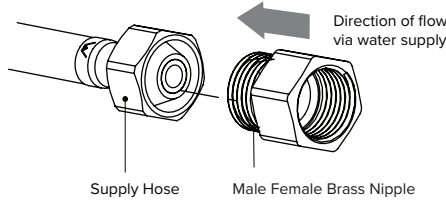
MAINS PRESSURE	EQUAL LOW PRESSURE
Install product as supplied.	Remove aerator from mixer outlet and replace with flow straightener together with filter mesh washer.
UNEQUAL PRESSURE	
<ol style="list-style-type: none"> OUTLET: Remove aerator from mixer and replace with flow straightener together with filter mesh washer. INLET: Fit COLD supply hose end with male female brass nipple with flow restrictor prefitted in the orientation shown. 	 <p>Supply Hose</p> <p>Male Female Brass Nipple with flow restrictor prefitted</p> <p>Direction of flow via water supply</p>

HOW TO INSTALL



If mixer is being installed on a vitreous china bench top, apply silicone sealant to the base ring to ensure a water-tight seal on the uneven surface.

- Cut a mounting hole 35mm in diameter. There must be a minimum 20mm width of flat around the hole.
- Screw the "HOT" supply hose (with RED marking) into left hand hole of mixer base.
- Screw the "COLD" supply hose into right hand hole of mixer base.
- Lower the fitted hoses, one hose at a time, into mounting hole.
- From UNDERNEATH the bench fit rubber gasket, metal gasket and a metal fixing nut. For more stability (or a thin benchtop) - fit white fixing triangle prior to fitting the fixing nut.
- Check the mixer and the benchtop seal are correctly aligned on the bench. Secure both screws with screwdriver.
- Flush the supply pipes to remove debris.
- Connect the water supply with the appropriate fittings and check all the fittings are tight.
- Turn on water supply and check for leaks.

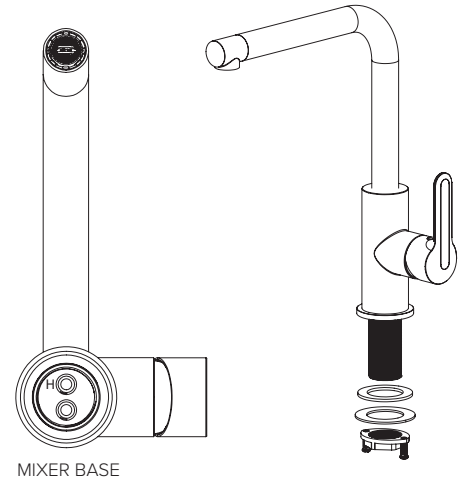

Maximum bend for flexible hose is 35mm radius.

The nipples on the hoses must be connected to fittings which have machined end faces, not "sawn off" threaded tube.

For technical assistance please ring
 NZ 0800 743 358 or (09) 528 0810 | AUS 1800 798 760