

# INSTALLATION GUIDE

FELTON

## FUSION PLUS® SHOWER MIXER

### SYSTEM REQUIREMENTS

	MINIMUM		MAXIMUM
	Hot	Cold	
Unequal Pressure - Venturi jet installed Operating Pressures - refer to the Venturi Selection Table on page 2	20kPa (2.9psi)	300kPa (43.5psi)	1500kPa (217.6psi)
Equal High (Mains) & Equal Low Pressures - Venturi jet removed Operating Pressures	36kPa (5.1psi)		1500kPa (217.6psi)
Operating Hot Water Temperatures	50° C		60° C
Operating Cold Water Temperatures	5° C		N/A

⚠ This mixer can be line tested up to 1500kPa (217.6psi).

⚠ Mixer must be in a closed position for line testing.

⚠ This mixer is recommended for all pressure situations.

To ensure the optimum performance and customer satisfaction please adhere to the following:

- Flush out all pipe work prior to installation.
- Maximum static water pressure: 1500kPa. If the water pressure exceeds or is likely to exceed 1500kPa, an approved pressure limiting valve must be fitted.
- Maximum hot water temperature: 60°C. If the water temperature is likely to exceed 60°C, an approved tempering valve must be fitted.
- Installation should comply with relevant local authority requirements.
- In accordance with good plumbing practice, filters should be fitted to supply lines to eliminate damage to the ceramic cartridge from suspended solids.
- AS/NZS 3500.1 states that pressures above 500kPa can cause damage from water hammer, reduce the life of appliances, taps & fittings, cause excessive noise in the system and recommend that a pressure limiting valve (PLV) be fitted.
- Installation must be carried out by a registered plumber in accordance with AS/NZS 3500, the New Zealand Building Code and Felton instructions.
- Inspection and maintenance must be carried out in accordance with Felton instructions to ensure ongoing performance and compliance.

⚠ Failure to comply with the above will void all warranties.

### WHAT IS IN THE PACK

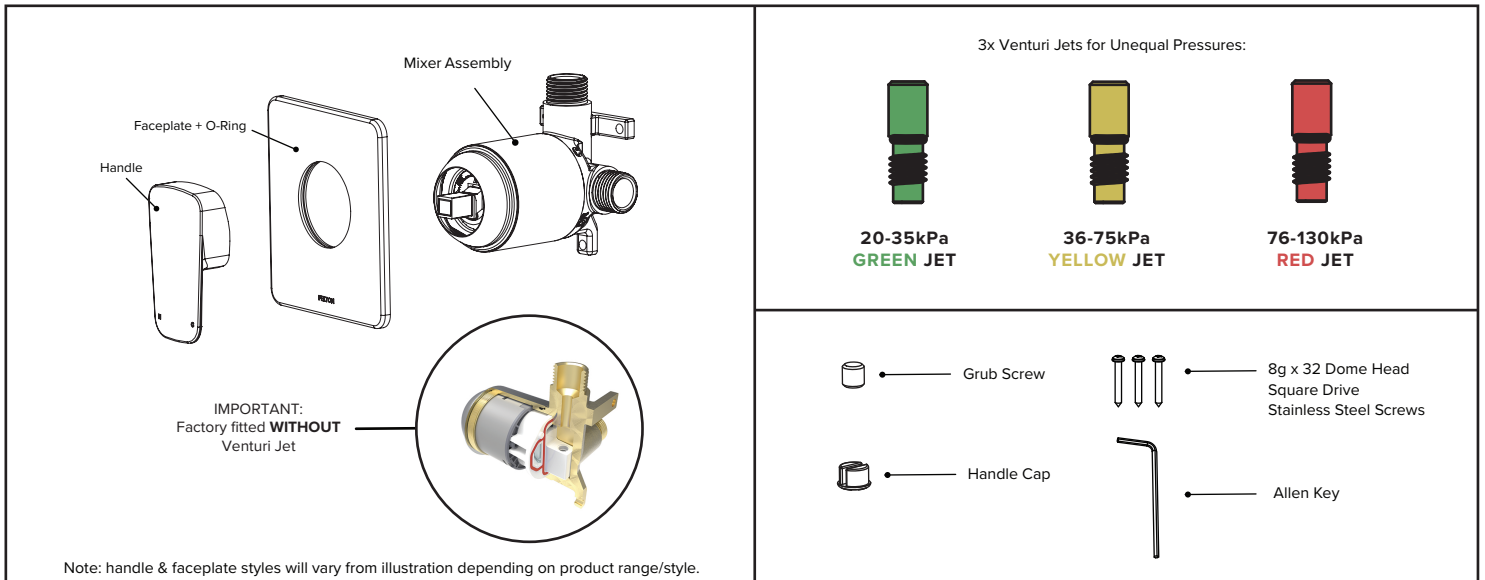

### ⚠ BEFORE INSTALLATION

Pipework MUST be purged before connecting to the mixer

### ⚠ MIXER ORIENTATION

This mixer is designed to be connected with the hot water supply on the left only and the cold water supply on the right only.

If at any point the cartridge nut is removed, please ensure that both black lines marked on the cartridge and cartridge nut are aligned when the mixer is in full cold position as shown in figure 1.

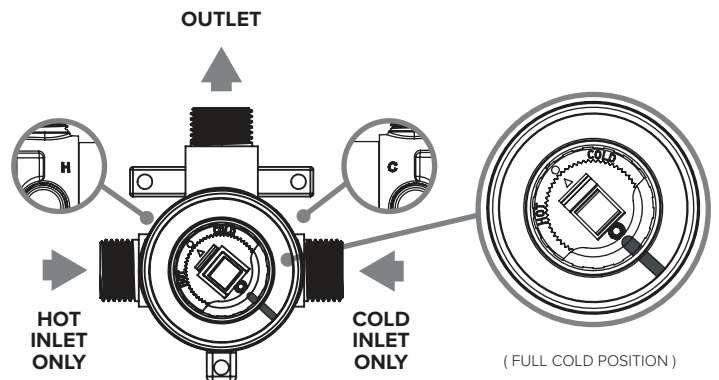
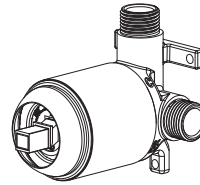

Figure 1.

IF YOU HAVE...

EQUAL LOW PRESSURE OR EQUAL HIGH/MAINS PRESSURE

Install product as supplied.



UNEQUAL PRESSURE

1. Check your hot & cold water pressure.
2. Follow this flowchart to select the correct Venturi Jet for the pressure situation:

	<p><b>20-35kPa GREEN JET</b> Recommended for 20-35kPa hot water supply.</p>		<p><b>36-75kPa YELLOW JET</b> Recommended for 36-75kPa or greater hot water supply.</p>		<p><b>76-130kPa RED JET</b> Recommended for 76-130kPa or greater hot water supply.</p>
--	---	--	---	--	--

  

<p><b>START:</b></p>	<p>COLD WATER PRESSURE:</p>									
	Unknown Water Pressure	<p><b>Yellow Jet</b> (Hot water pressure 20kPa – 130kPa)</p>								
	More than 500kPa	<p><b>Yellow Jet</b> (Hot water pressure 20kPa – 130kPa)</p>								
	150 - 500kPa	<table border="1"> <tr> <td colspan="2" style="background-color: #333; color: white; text-align: center;"> <p>HOT WATER PRESSURE:</p> </td> </tr> <tr> <td style="text-align: center;">20 - 35kPa</td> <td style="text-align: center;"> <p><b>Green Jet</b></p> </td> </tr> <tr> <td style="text-align: center;">36 - 75kPa</td> <td style="text-align: center;"> <p><b>Yellow Jet</b></p> </td> </tr> <tr> <td style="text-align: center;">76 - 130kPa</td> <td style="text-align: center;"> <p><b>Red Jet</b></p> </td> </tr> </table>	<p>HOT WATER PRESSURE:</p>		20 - 35kPa	<p><b>Green Jet</b></p>	36 - 75kPa	<p><b>Yellow Jet</b></p>	76 - 130kPa	<p><b>Red Jet</b></p>
	<p>HOT WATER PRESSURE:</p>									
	20 - 35kPa	<p><b>Green Jet</b></p>								
36 - 75kPa	<p><b>Yellow Jet</b></p>									
76 - 130kPa	<p><b>Red Jet</b></p>									

**Please note:** Performance of the mixer will vary based on the specific pipework between your hot water source and the outlet.

INSTALLING THE VENTURI JET:

Using the Allen Key provided, screw the Venturi Jet into the inlet thread end first. The Allen Key is a tight fit and will require a hard push to fully engage in the jet.

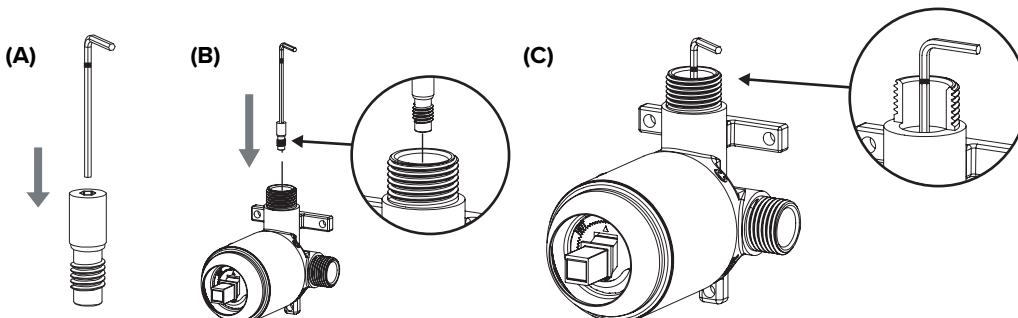

**IMPORTANT**

Ensure the Venturi Jet is screwed in firmly thread end first until the mark on the key aligns with the end of the mixer outlet.

*Please note:*  
Do not throw away the other Venturi Jets as they may be required at a later date. Ask the homeowner to keep with the warranty information.

HOW TO INSTALL

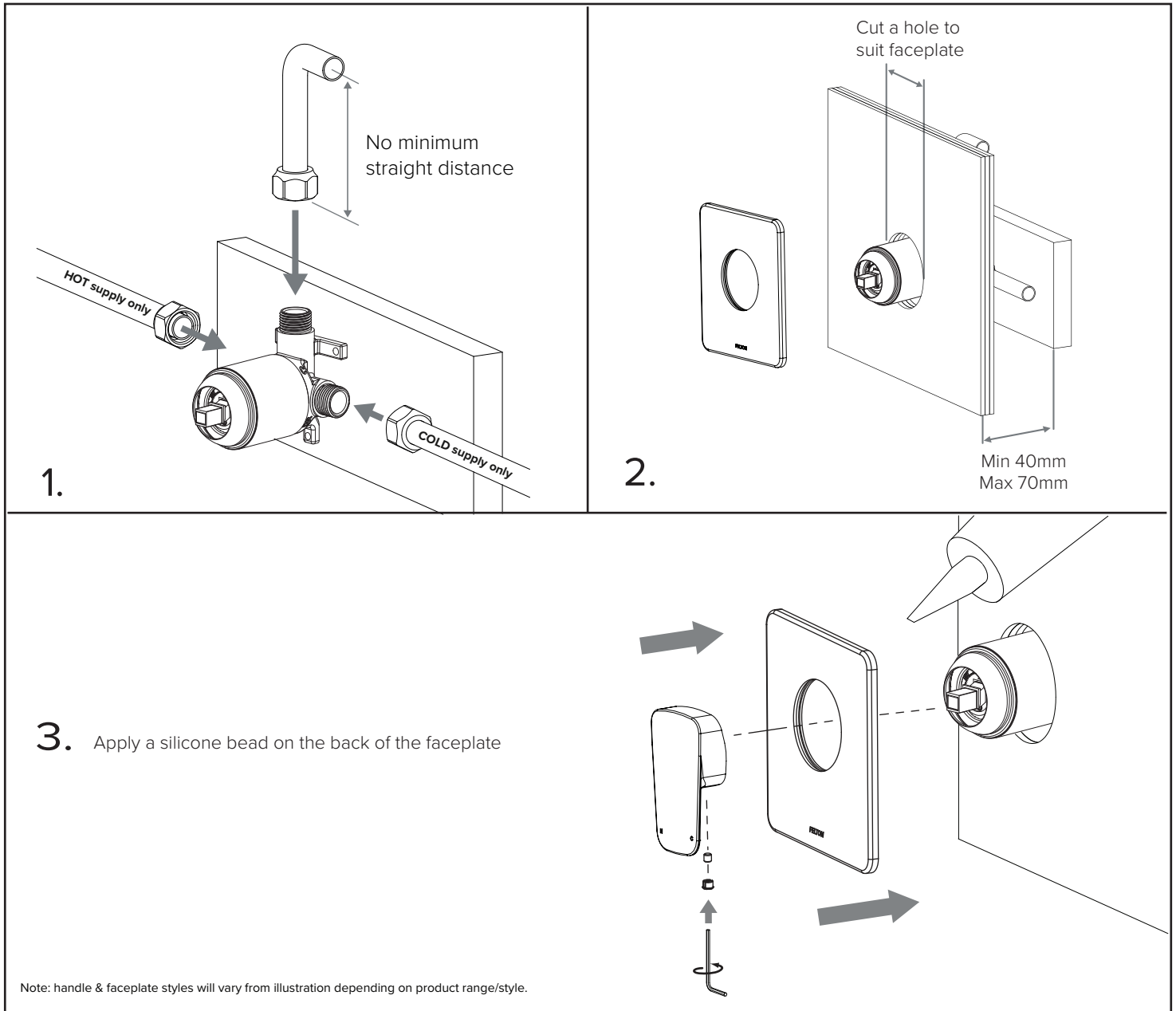

**TROUBLESHOOTING - SWAPPING OUT THE VENTURI JETS**

1. Remove the handle and disassemble the mixer:

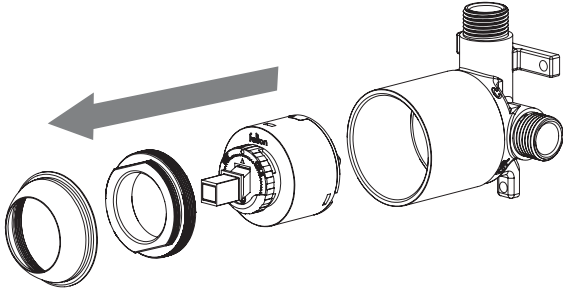

2. Remove the insert disc using long nose pliers by carefully inserting the nose of the pliers into the indicated areas A & B.

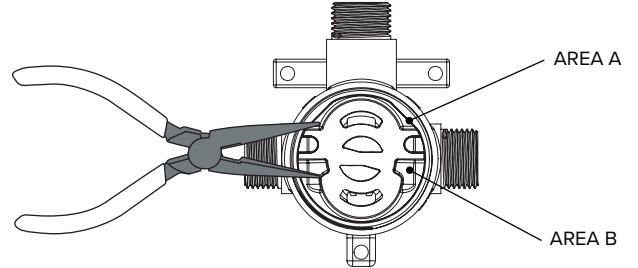

3. Unscrew the Venturi Jet using an Allen Key

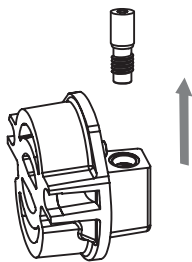

4. Refit the correct Venturi Jet into the insert disc and hand tighten firmly

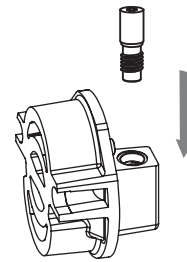

5. Refit the seal with silicone grease if required and then insert disc using the long nose pliers, ensuring that the locating pins go into the corresponding sockets.

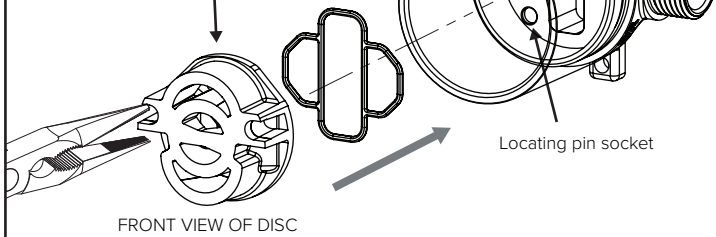
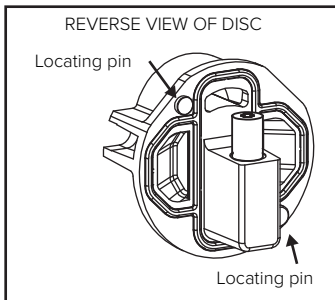

6. Reassemble mixer. Ensure that both black lines marked on the cartridge and cartridge nut are aligned when the mixer is in full cold position as shown in Figure 1.

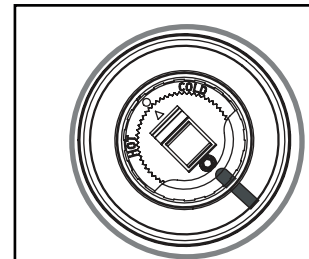
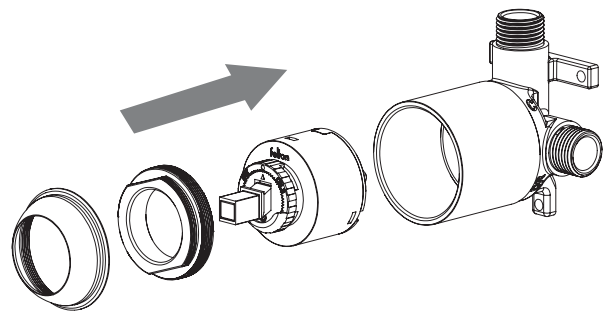

( FULL COLD POSITION )

**Figure 1.**

**UPGRADING FROM UNEQUAL TO MAINS PRESSURE**

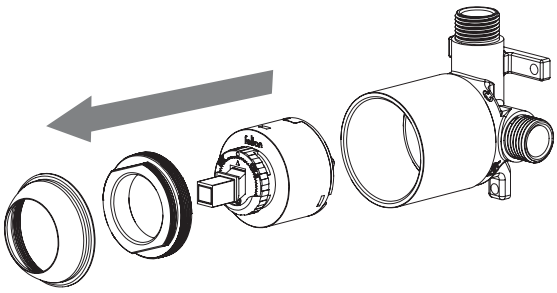
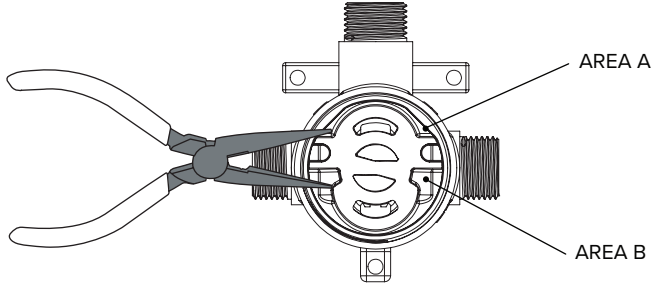
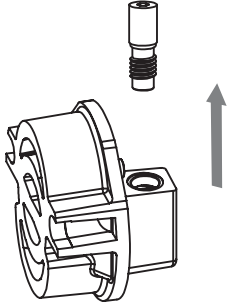
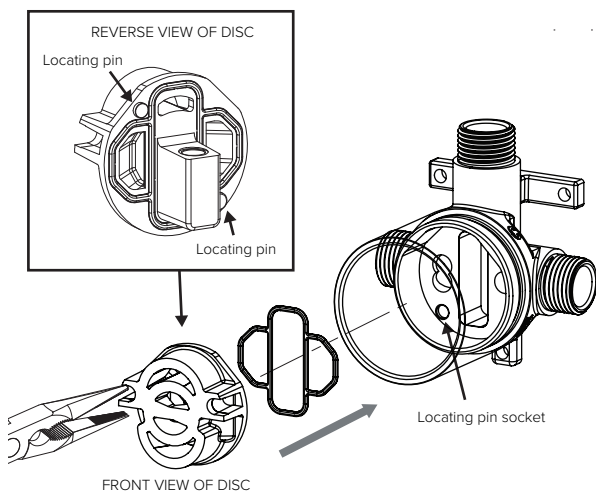
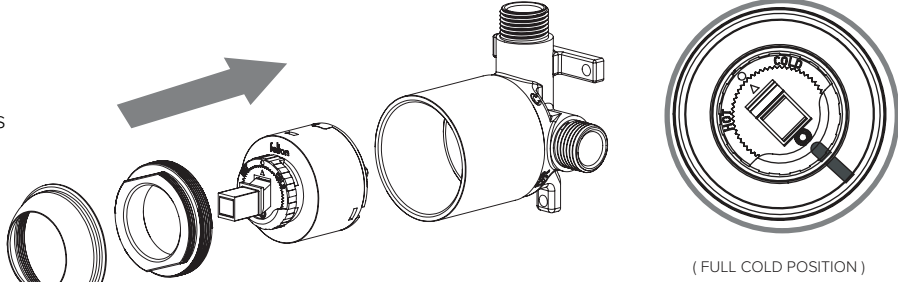
<p>1. Remove the handle and disassemble the mixer:</p> 	<p>2. Remove the insert disc using long nosed pliers by carefully inserting the nose of the pliers into the indicated areas A &amp; B.</p> 
<p>3. Unscrew the Venturi Jet using an Allen Key</p> 	<p>4. Refit the seal with silicone grease if required and then insert disc using the long nose pliers, ensuring that the locating pins go into the corresponding sockets.</p> 
<p>5. Reassemble mixer. Ensure that both black lines marked on the cartridge and cartridge nut are aligned when the mixer is in full cold position as shown in Figure 1.</p>  <p style="text-align: right;"><b>Figure 1.</b></p>	

**MAINTENANCE - CLEANING THE FILTER**

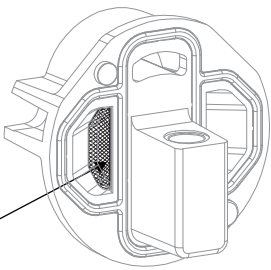
<p>1. Follow steps 1-2 above.          2. Flush out the disc in cold water.          3. Follow steps 4-5 above.</p>	 <p style="text-align: right;">REVERSE VIEW OF DISC</p>
---	--

**BUILDING PRODUCT INFORMATION REQUIREMENTS (BPIR)**  
RELEVANT BUILDING CODE CLAUSES & CONTRIBUTIONS TO COMPLIANCE

This product is Watermarked under license **WM25208 - Tapware (Lead free) AS 3718: 2021**

**B2 - Durability****B2.3.1 (c) applies (performance of building elements)**

Proof of durability – Service history: Felton products have been installed and used in NZ for the last 50 years and warranty calls are at a minimum and within the quality principles of Felton.

Products that are WaterMark certified are subject to endurance testing.

**F2 - Hazardous building materials****F 2.3.1 applies (performance)**

Products in contact with drinking water is tested to AS/NZS 4020 (ensures acceptance levels of contaminants for human consumption). Compliance with Lead Free and DR Lead Free requirements where applicable.

**G12 - Water Supplies****G12.2 applies (materials)**

Felton products in contact with drinking water are tested to AS/NZS 4020, ensuring no water contamination and compliance with Lead Free and DR Lead Free requirements where applicable.

**G12.3.2 applies (contamination of water)**

All Felton products are designed, manufactured and inspected/tested, that are WaterMark certified, are subject to contamination of water testing (AS/NZS 4020). Compliance with Lead Free requirements where applicable.

**G12.3.5 applies (performance)**

Felton sanitary fixtures intended for utensil washing and personal washing, showering, or bathing are designed to be connected to a hot water supply and tested to AS/NZS 4020, ensuring suitability for potable water, non-contamination, and compliance with the performance requirements of NZ Building Code G12.

**G12.3.7 (c) applies (flow rates)**

All Felton products are designed, manufactured and inspected/tested, that are WaterMark certified, are subject to flow rates testing that is within the limitation set by the AS/NZS 3500 (NZBC) and the WELS regulations.

**G12.3.10 applies (performance)**

Felton water supply taps are designed to be accessible and operable, including for people with disabilities, when installed in accordance with Felton's instructions, supporting compliance with the accessibility requirements of the NZ Building Code.

For technical assistance please ring: 0800 743 358 or (09) 528 0810