

# INSTALLATION GUIDE

## LINEA SPRING SINK MIXER

### SYSTEM REQUIREMENTS

To ensure the optimum performance and customer satisfaction please adhere to the following:

- Flush out all pipe work prior to installation.
- Maximum hot water temperature is 60°C. If the water temperature exceeds 60°C an approved tempering valve must be fitted.
- Installation should comply with relevant local authority requirements.
- In accordance with good plumbing practice, filters should be fitted to supply lines to eliminate damage to the ceramic cartridge from suspended solids.
- AS/NZS 3500.1 states that pressures above 500kPa can cause damage from water hammer, reduce the life of appliances, taps & fittings, cause excessive noise in the system and recommend that a pressure limiting valve (PLV) be fitted.
- Backflow protection must be provided in accordance with AS/NZS 3500 and local authority requirements, as assessed and installed by a registered plumber; backflow devices may or may not be supplied depending on product.
- Installation must be carried out by a registered plumber in accordance with AS/NZS 3500, the New Zealand Building Code and Felton instructions.
- Inspection and maintenance must be carried out in accordance with Felton instructions to ensure ongoing performance and compliance.

<b>MAXIMUM STATIC PRESSURE</b>	<b>MINIMUM STATIC PRESSURE</b>	HOT	COLD
Maximum static pressure 1500kPa. If water pressure exceeds or is likely to exceed 1500kPa, an approved pressure limiting valve must be fitted.	Mains Pressure	150kPa	150kPa



**Failure to comply with the above will void warranties**

### BUILDING PRODUCT INFORMATION REQUIREMENTS (BPIR)

#### RELEVANT BUILDING CODE CLAUSES & CONTRIBUTIONS TO COMPLIANCE

This product is Watermarked under license **WM25208 - Tapware (Lead free) AS 3718: 2021 (Pending)**

#### **B2 - Durability**

##### **B2.3.1 (c) applies (performance of building elements)**

Proof of durability – Service history: Felton products have been installed and used in NZ for the last 50 years and warranty calls are at a minimum and within the quality principles of Felton.

Products that are WaterMark certified are subject to endurance testing.

#### **F2 - Hazardous building materials**

##### **F 2.3.1 applies (performance)**

Products in contact with drinking water is tested to AS/NZS 4020 (ensures acceptance levels of contaminants for human consumption). Compliance with Lead Free and DR Lead Free requirements where applicable. Backflow protection must be provided in accordance with AS/NZS 3500 and local authority requirements, as assessed and installed by a registered plumber; backflow devices may or may not be supplied depending on product.

#### **G12 - Water Supplies**

##### **G12.2 applies (materials)**

Felton products in contact with drinking water are tested to AS/NZS 4020, ensuring no water contamination and compliance with Lead Free and DR Lead Free requirements where applicable.

##### **G12.3.2 applies (contamination of water)**

All Felton products are designed, manufactured and inspected/tested, that are WaterMark certified, are subject to contamination of water testing (AS/NZS 4020). Compliance with Lead Free requirements where applicable.

##### **G12.3.5 applies (performance)**

Felton sanitary fixtures intended for utensil washing and personal washing, showering, or bathing are designed to be connected to a hot water supply and tested to AS/NZS 4020, ensuring suitability for potable water, non-contamination, and compliance with the performance requirements of NZ Building Code G12.

##### **G12.3.7 (c) applies (flow rates)**

All Felton products are designed, manufactured and inspected/tested, that are WaterMark certified, are subject to flow rates testing that is within the limitation set by the AS/NZS 3500 (NZBC) and the WELS regulations.

##### **G12.3.10 applies (performance)**

Felton water supply taps are designed to be accessible and operable, including for people with disabilities, when installed in accordance with Felton’s instructions, supporting compliance with the accessibility requirements of the NZ Building Code.

**WHAT IS IN THE PACK**

1 x sink mixer	1 x sink fixing kit
2 x supply hoses	1 x mounting support (triangle)
1 x flange & bench top o-ring	2 x dual check valves

**MOUNTING OPTIONS**

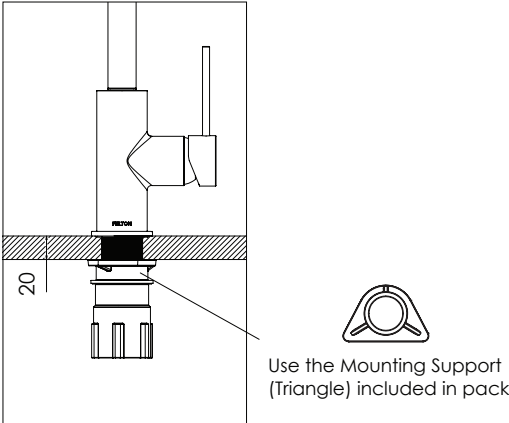
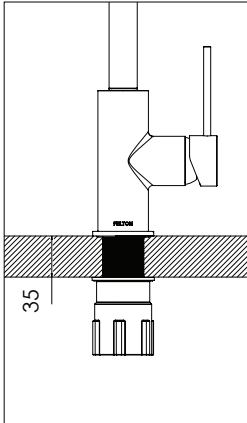
<p>1. When installing <u>with</u> the Mounting Support</p>	<p>2. When installing <u>without</u> the Mounting Support</p>
<p>PREFERRED MOUNTING SCENARIO Maximum thickness = 20mm</p> 	<p>Maximum thickness = 35mm</p> 

For technical assistance please ring  
 NZ 0800 743 358 or (09) 528 0810 | AUS 1800 798 760

## HOW TO INSTALL



If mixer is being installed on a vitreous china bench top, apply silicone sealant to the base ring to ensure a water-tight seal on the uneven surface.

1. Cut a mounting hole 35mm in diameter. There must be a minimum 80mm distance from the center of the hole to the wall (diagram A).
2. Fit bench top o-ring to the flange. Fit the flange to the base of the mixer.
3. Screw the "HOT" supply hose (with red marking) into mixer (with red marking) (diagram B).
4. Screw the "COLD" supply hose (unmarked) into the last hole in the mixer.
5. Lower the fitted hoses, one hose at a time, into mounting hole.
6. From UNDERNEATH the bench, fit the fixing kit as shown in the Fit the Dual Check Valve on both hot and cold water supply. (diagram C). (mounting support may be required for better stability).
7. Tighten the mounting tube.
8. Fit the Dual Check Valve on both hot and cold water supply (diagram D).
9. Check the mixer and flange are correctly aligned on the bench. Hand tighten the mounting tube.
10. Flush the supply pipes to remove debris.
11. Connect the water supply with the appropriate fittings and check all the fittings are tight.
12. Turn on water supply and check for leaks.

**Maximum bend for flexible hose is 35mm radius. The nipples on the hoses must be connected to fittings which have machined end faces, not "sawn off" threaded tube.**

