

INSTALLATION GUIDE

MAINS PRESSURE SHOWER MIXER

SYSTEM REQUIREMENTS	MINIMUM	MAXIMUM
Equal Pressures Operating Pressures	20kPa (2.9psi)	1500kPa (217.6psi)
Operating Hot Water Temperatures	50° C	60° C
Operating Cold Water Temperatures	5° C	N/A

⚠ This mixer can be line tested up to 1500kPa (217.6psi)

⚠ Mixer must be in a closed position for line testing.

⚠ This mixer is recommended for equal low & equal high (mains) pressure water supply only.

To ensure the optimum performance and customer satisfaction please adhere to the following:

- Flush out all pipe work prior to installation.
- Minimum flow pressure for satisfactory operation: (Hot and Cold) 20kPa.
- Maximum static water pressure: 1500kPa. If the water pressure exceeds or is likely to exceed 1500kPa, an approved pressure limiting valve must be fitted.
- Maximum hot water temperature: 60°C. If the water temperature exceeds 60°C, an approved tempering valve must be fitted.
- Installation should comply with relevant local authority requirements.
- In accordance with good plumbing practice, filters should be fitted to supply lines to eliminate damage to the ceramic cartridge from suspended solids.
- AS/NZS 3500.1 states that pressures above 500kPa can cause damage from water hammer, reduce the life of appliances, taps & fittings, cause excessive noise in the system and recommend that a pressure limiting valve (PLV) be fitted.
- Installation must be carried out by a registered plumber in accordance with AS/NZS 3500, the New Zealand Building Code and Felton instructions.
- Inspection and maintenance must be carried out in accordance with Felton instructions to ensure ongoing performance and compliance.

⚠ Failure to comply with the above will void all warranties.

BUILDING PRODUCT INFORMATION REQUIREMENTS (BPIR)

RELEVANT BUILDING CODE CLAUSES & CONTRIBUTIONS TO COMPLIANCE

This product is Watermarked under license **WM25208 - Tapware (Lead free) AS 3718: 2021**

B2 - Durability

B2.3.1 (c) applies (performance of building elements)

Proof of durability – Service history: Felton products have been installed and used in NZ for the last 50 years and warranty calls are at a minimum and within the quality principles of Felton.

Products that are WaterMark certified are subject to endurance testing.

F2 - Hazardous building materials

F 2.3.1 applies (performance)

Products in contact with drinking water is tested to AS/NZS 4020 (ensures acceptance levels of contaminants for human consumption). Compliance with Lead Free and DR Lead Free requirements where applicable.

G12 - Water Supplies

G12.2 applies (materials)

Felton products in contact with drinking water are tested to AS/NZS 4020, ensuring no water contamination and compliance with Lead Free and DR Lead Free requirements where applicable.

G12.3.2 applies (contamination of water)

All Felton products are designed, manufactured and inspected/tested, that are WaterMark certified, are subject to contamination of water testing (AS/NZS 4020). Compliance with Lead Free requirements where applicable.

G12.3.5 applies (performance)

Felton sanitary fixtures intended for utensil washing and personal washing, showering, or bathing are designed to be connected to a hot water supply and tested to AS/NZS 4020, ensuring suitability for potable water, non-contamination, and compliance with the performance requirements of NZ Building Code G12.

G12.3.7 (c) applies (flow rates)

All Felton products are designed, manufactured and inspected/tested, that are WaterMark certified, are subject to flow rates testing that is within the limitation set by the AS/NZS 3500 (NZBC) and the WELS regulations.

G12.3.10 applies (performance)

Felton water supply taps are designed to be accessible and operable, including for people with disabilities, when installed in accordance with Felton’s instructions, supporting compliance with the accessibility requirements of the NZ Building Code.

WHAT IS IN THE PACK

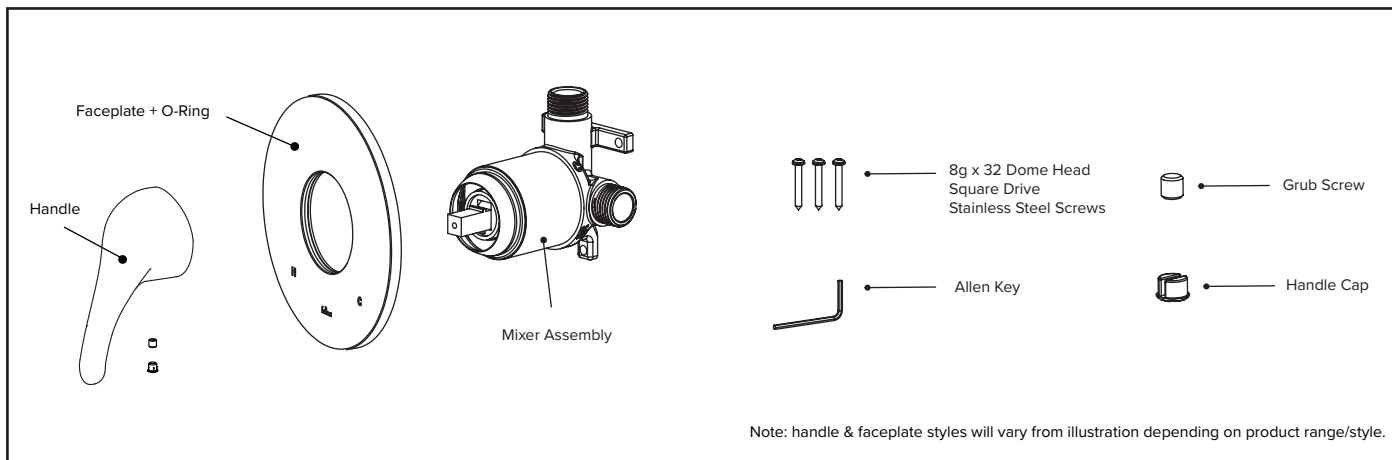

BEFORE INSTALLATION

Pipework **MUST** be purged before connecting to the mixer

HOW TO INSTALL

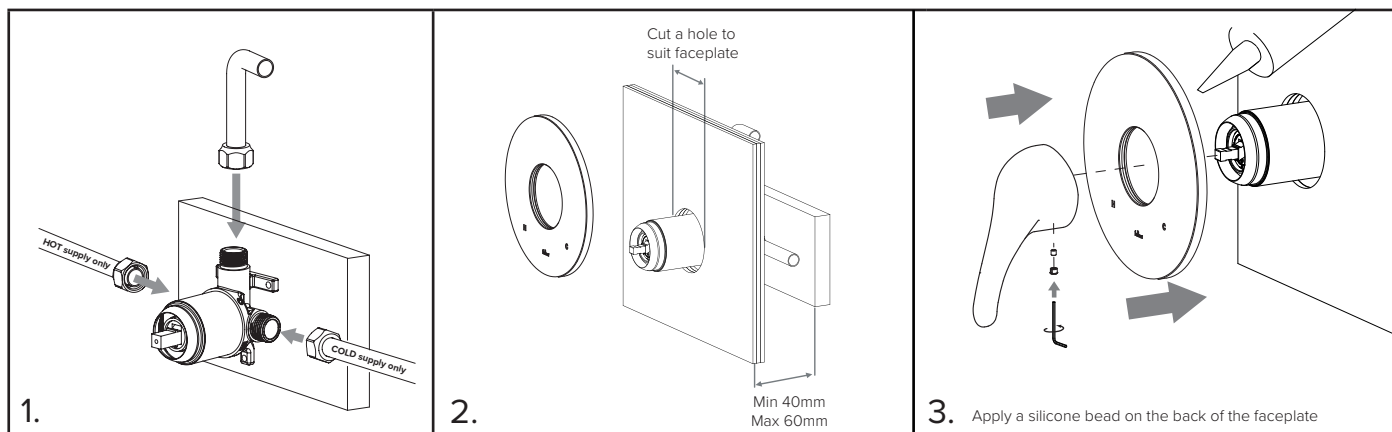

Note: handle & faceplate styles will vary from illustration depending on product range/style.

For technical assistance please ring
 NZ 0800 743 358 or (09) 528 0810 | AUS 1800 798 760